

Wieland

**Finned Tube Heat Exchangers
Type WRW and WRW-W**

Wieland Thermal Solutions®
PROVIDING EFFICIENCY

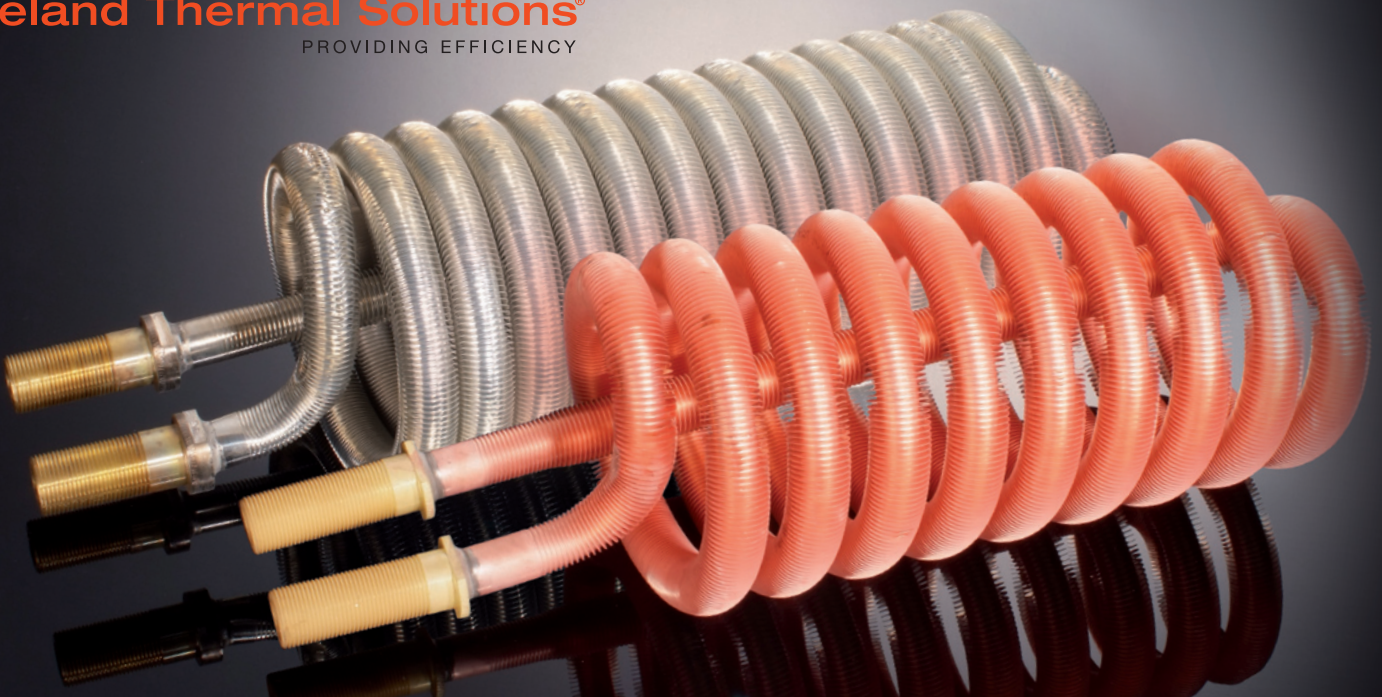

Finned Tube Heat Exchangers Type WRW and WRW-W

WRW finned tube heat exchangers are mainly used for the heating of drinking or heating water and as tankless water heaters. They are also suitable for heating or cooling other liquids (suitability of material to be checked on a case-by-case basis).

WRW-W finned tube heat exchanger are primarily used for solid-fuel boilers (see DIN 47, sheet 2: Safety requirements for heating systems with flow temperature up to 110 °C).

For the type WRW-W a GEWA-DW finned tube with integral fins is used. Due to the integral fins the pressure drop is approximately 1.8–1.9 times higher compared to the type WRW.

Manufacturing and Processing

WRW is a spiral heat exchanger consisting of a seamless copper tube having integral fins (GEWA-D) and brazed fittings. It is pressure tested at 28 bar according to the "air under water" method.

The risk of corrosion of galvanized steel tubes connected Downstream can be reduced by tin plating the outside surface of the finned tube heat exchanger. If drinking water flows in the heat exchanger, inside nickel plating is recommended. WRW heat exchangers with tin plated surface are available from stock; inside plating upon request only.

Benefits

- Option of compact design through high thermal conductivity of copper in combination with optimised heat transfer surface
- Proven corrosion resistance of copper materials for drinking water, particularly chloride-containing water
- Copper – a hygienic and antimicrobial material for use in drinking water storage
- Exchangeable via compact coil design
- Standard heat exchangers available from stock
- Can be adapted to your individual requirements as necessary

Materials

Part	Material designation	Composition as per	Wieland symbol
Finned tube	Cu-DHP	EN 12449	K21
Connecting pieces	CuZn36Pb2As	EN 12164	Z45
Hard solder	AG106	EN 1044	
Sealing element	EPDM	DIN ISO 1629	
Hollow disk	CuZn36Pb2As	EN 12164	Z45
Hexagon nut	CuZn36Pb2As	EN 12164	Z45

Operation

Heating fluids	Boiler, district heating or heat-pump water
	Superheated vapour
	Halocarbons (Antifrogen N, PKL 90)
	Others upon enquiry
Max. operating temperature for EPDM-Sealing element*	Up to +130 °C; up to +170 °C for a short time
Max. operating gauge pressure	28 bar

*Do not use lubricants which contain mineral oil!

Dimensions and Weights

Model	Finned tube GEWA-D				D _{max}	a _{max}	b*	Dimensions (mm)							Aprox. weight (kg)
	Tube No.	Tube length (mm)	Outer surface area (m ²)	Free-space sectional area (cm ²)				e	f	g	D	SW	G	m	
WRW 10	D-1135.12100-00	5210	1.0	0.78	140	350	295	62	35	–	30	24	½"	8	3.6
WRW 13	D-1135.14100-00	5780	1.3	1.13	147	410	330	62	35	–	35	27	¾"	10	4.7
WRW 16**	D-1135.16100-00	6700	1.6	1.65	160	440	370	62	35	–	35	27	¾"	10	6.3
WRW 18	D-1135.18100-00	6590	1.8	2.13	170	440	360	62	35	–	35	27	¾"	10	6.7
WRW 23	D-1135.18100-00	8380	2.3	2.13	170	540	460	62	35	–	35	27	¾"	10	8.4
WRW 26	D-1135.18100-00	9290	2.6	2.13	170	590	505	62	35	–	35	27	¾"	10	9.3
WRW 26-2	D-1135.18100-00	9300	2.7	4.26	175	510	460	65	65	45	45	35	1"	11	9.8
WRW 31-2	D-1135.18100-00	11000	3.1	4.26	175	540	490	65	65	45	45	35	1"	11	11.5
WRW 36-2	D-1135.18100-00	13300	3.6	4.26	175	650	580	65	65	45	45	35	1"	11	13.9
WRW 45-2	D-1135.18100-00	16880	4.5	4.26	175	790	710	65	65	45	45	35	1"	11	17.3

*approximate dimensions

**not available from stock

Quality Assurance

To ensure consistent product quality, Wieland-Werke AG has a sophisticated quality control system according to DIN EN ISO 9001:2000 which has been verified and certified by the independent certification company, Bureau Veritas Quality International (BVQI). Since 30 December 2002, our test laboratories in the Central Laboratory and Development Services have been accredited to DIN EN ISO/IEC 17025 and DIN EN ISO 9001 as test and certification laboratories.

Technical Service

Our Technical Marketing experts are available at any time as contact partners to work together with your experts from the very early product planning stages in order to obtain optimum results for the manufacturing stage and for your application. The only way to find the best, most economical solution is by means of comprehensive technical consultation based on thermal engineering rating.

Type WRW

WRW 10 to WRW 26

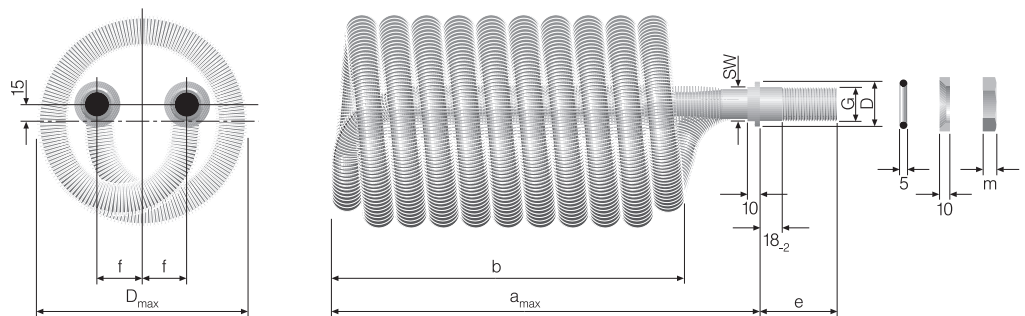

WRW 26-2 to WRW 45-2

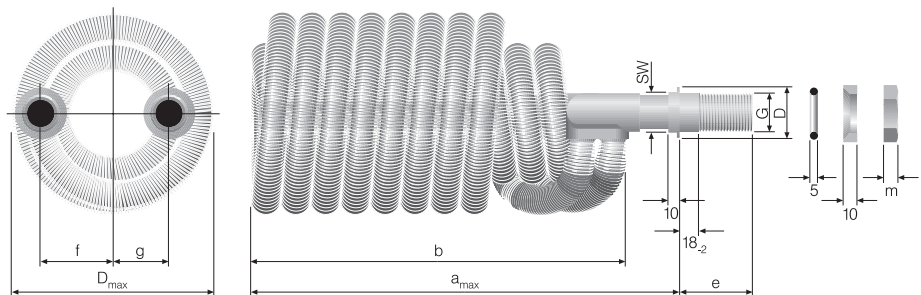

Capacity and Pressure Drop

The diagrams on the following pages will be helpful when choosing a heat exchanger to heat a water tank using the water of a heating circuit. The diagrams are based on our own tests with heating water and unforced convection of the tank water.

Symbols:

\dot{Q} (W) Capacity to be transferred

\dot{q} (W/K) Capacity per K of temperature difference ($t_1 - t_s$)

t_1 (°C) Heating water temperature at inlet

t_2 (°C) Heating water temperature at outlet

t_s (°C) Mean temperature of tank water surrounding the heat exchanger

\dot{V} (m³/s) Heating water volume flow

w (m/s) Heating water velocity (limit 2.5 m/s)

Δp (bar) Pressure drop on heating water side

f_1 (-) Correction factor for lower capacity when using other heating fluids

f_2 (-) Correction factor for pressure drop increase when using other heating fluids

Index G Other heating fluid (mixture)

With water as heating fluid, the capacity to be transferred is:

$$\dot{Q} = \dot{q} (t_1 - t_s)$$

The pressure drop in the heat exchanger is given in the diagram on page 4.

With heating fluids (mixtures) as used in solar power units, the capacity drops by the factor f_1 and the pressure drop rises by the factor f_2 :

$$\dot{Q}_G = f_1 \cdot \dot{q} (t_1 - t_s)$$

$$\Delta p_G = f_2 \cdot \Delta p$$

Factors of a few commercial heating fluids (mixtures):

	f_1	f_2
Antifrogen N (concentration 20 %)	0.95	1.15
Antifrogen N (concentration 40 %)	0.85	1.35
PKL 90 (concentration 100 %)	0.55	1.45

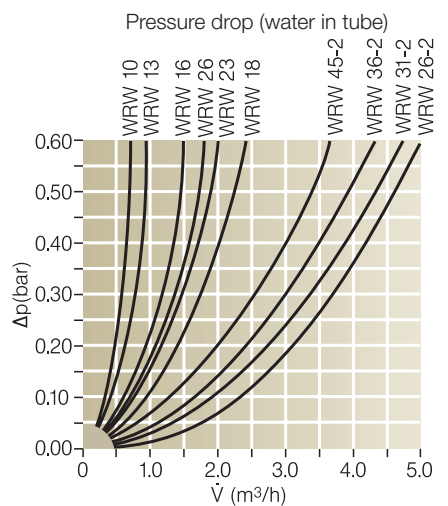
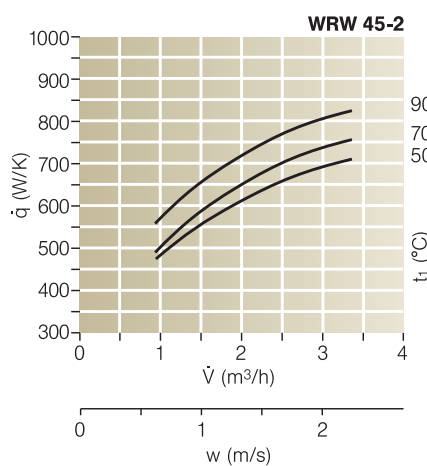
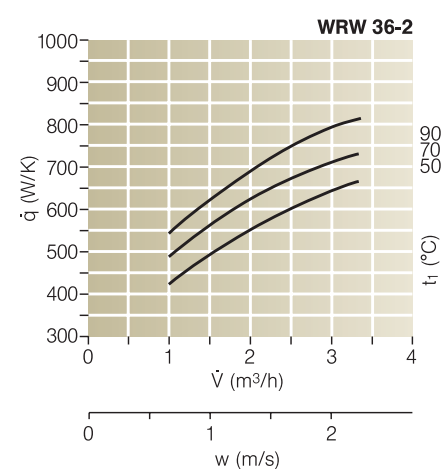
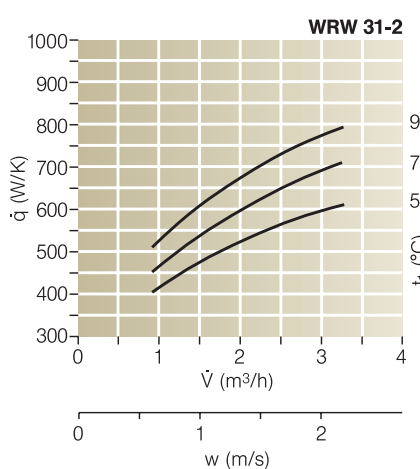
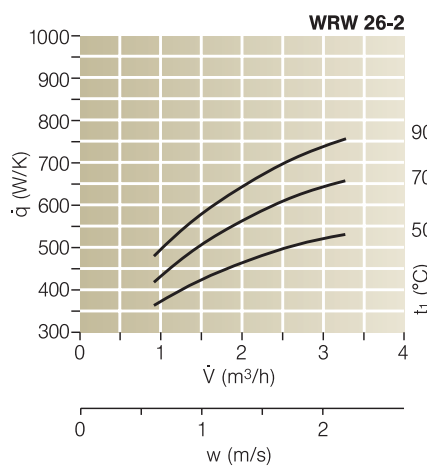
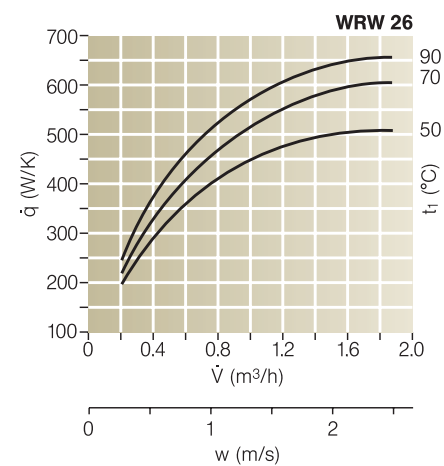
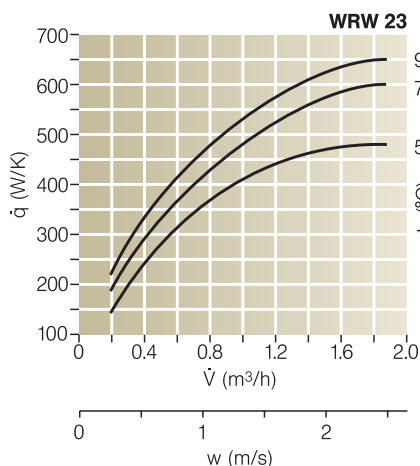
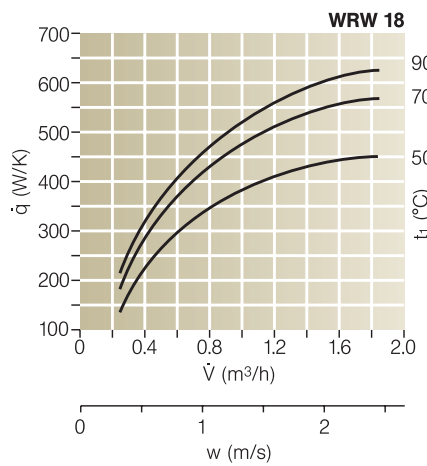
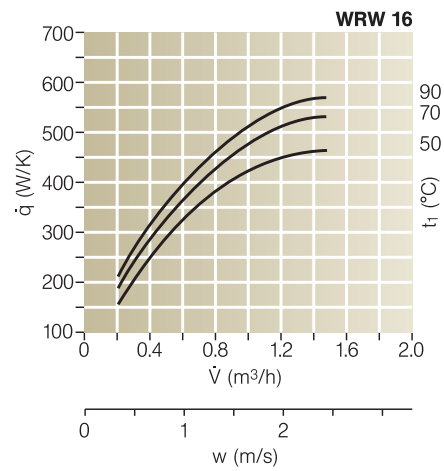
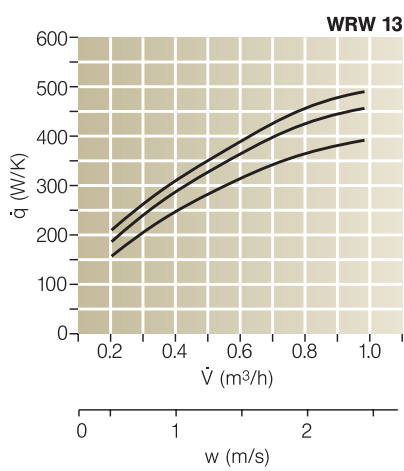
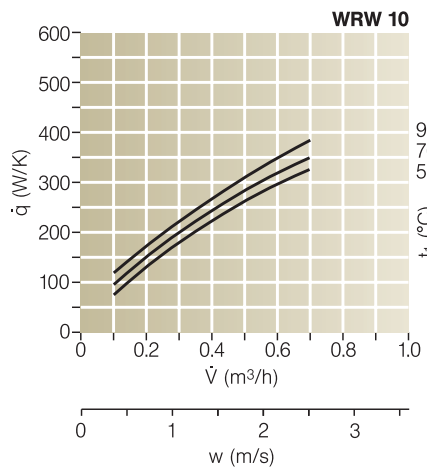

Example

A 300 l water tank is to be reheated through a solar power system filled with a 40 % Antifrogen N solution. The heating fluid enters the tank at 50 °C to reheat the 15 °C tank water. The volume flow is 1.0 m³/h and the maximum pressure drop in the heat exchanger is 0.3 bar.

a)

What is the capacity a specific heat exchanger can transfer to the tank water?

Solution a)

Maximum pressure drop for a 40 % Antifrogen N solution: 0.3 bar. Maximum pressure drop for water:

$$\Delta p = \frac{\text{max. } \Delta p_G}{f_2} = \frac{0.3}{1.35} = 0.22 \text{ bar}$$

Refer to pressure drop diagram:

Δp max. 0.22 bar and \dot{V} 1.0 m³/h, hence WRW 23 or WRW 26.

Refer to diagrams WRW 23 and WRW 26:

\dot{V} 1.0 m³/h, $t_1 = 50$ °C, hence

WRW 23: $\dot{q} = 410$ W/K

WRW 26: $\dot{q} = 440$ W/K

Capacity: $\dot{Q}_G = f_1 \cdot \dot{q} (t_1 - t_g)$:

WRW 23: $\dot{Q}_G = 0.85 \cdot 410 (50 - 15) = \text{approx. } 12 \text{ kW}$

WRW 26: $\dot{Q}_G = 0.85 \cdot 440 (50 - 15) = \text{approx. } 13 \text{ kW}$

b)

What is the pressure drop to be kept in mind when selecting the circulation pump?

Solution b)

$\Delta p_G = f_2 \cdot \Delta p$; (see Δp diagram)

WRW 23: $\Delta p_G = 1.35 \cdot 0.16 = 0.22 \text{ bar}$

WRW 26: $\Delta p_G = 1.35 \cdot 0.19 = 0.26 \text{ bar}$

c)

What is the return temperature of the heating fluid?

Solution c)

In the heat exchanger, the heating fluid cools off by

$$\Delta t = \frac{\dot{Q}_G}{\dot{V} \cdot \rho \cdot C_p}$$

Physical properties for the 40 % Antifrogen N heating fluid:

$\sigma = 1,055 \text{ kg/m}^3$; $C_p = 0.986 \text{ Wh/kgK}$

$$\text{WRW 23: } \Delta t = \frac{12,000}{1.0 \cdot 1,055 \cdot 0.986} = 11.5 \text{ K}$$

Rücklauftemperatur $t_2 = 50 - 11,5 = 38,5$ °C

$$\text{WRW 26: } \Delta t = \frac{13,000}{1.0 \cdot 1,055 \cdot 0.986} = 12.5 \text{ K}$$

Return temperature $t_2 = 50 - 12.5 = 37.5$ °C

d)

What capacity can be transferred when the temperature of the water surrounding the heat exchanger is 45 °C?

Solution d)

The water temperature around the heat exchanger is 45 °C, the capacity is only $\dot{Q}_G = f_1 \cdot \dot{q} (t_1 - t_g)$:

WRW 23: $\dot{Q}_G = 0.85 \cdot 410 (50 - 45) = \text{approx. } 1.75 \text{ kW}$

WRW 26: $\dot{Q}_G = 0.85 \cdot 440 (50 - 45) = \text{approx. } 1.9 \text{ kW}$

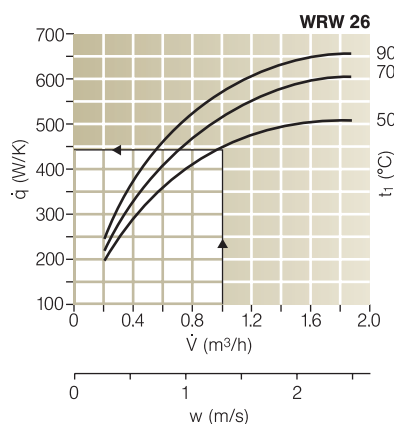
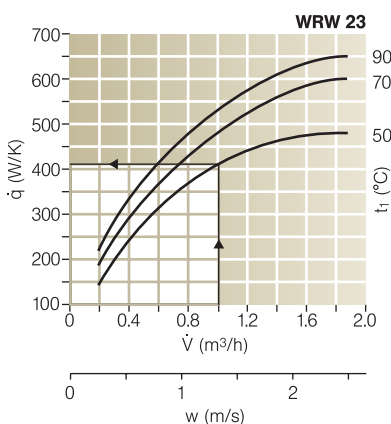

Pressure drop (water in tube)

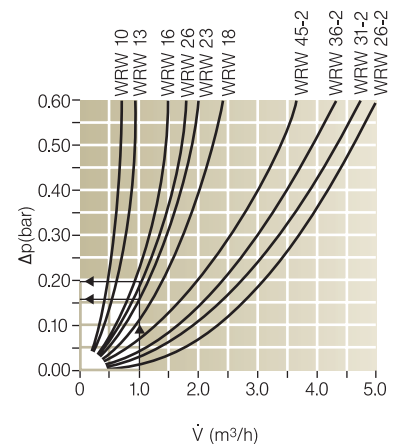

Typ WRW-W

WRW-10W – WRW-26W

Dimensions and Weights

Modell	Outer surface area	Finned tube GEWA-DW			Dimensions (mm)								Approx. weight
		Tube-No.	Tube-length (mm)	Free-space sectional area (cm ²)	D _{max}	a _{max}	b*	e	m	G	SW	D	
WRW-10W (SWW 10)	1.0	1145.12100-16	3800	0.70	140	350	320	46	8	R1½"	24	30	3.1
WRW-13W (SWW 13)	1.1	1145.14100-16	3950	1.05	147	410	375	52	10	R¾"	30	36	3.8
WRW-18W (SWW 18)	1.6	1145.18100-16	4430	1.90	170	440	390	52	10	R¾"	30	36	5.4
WRW-23W (SWW 23)	2.0	1145.18100-16	5830	1.90	170	540	490	52	10	R¾"	30	36	7.0
WRW-26W (SWW 26)	2.4	1145.18100-16	6750	1.90	170	595	545	52	10	R¾"	30	36	8.1

* approximate size

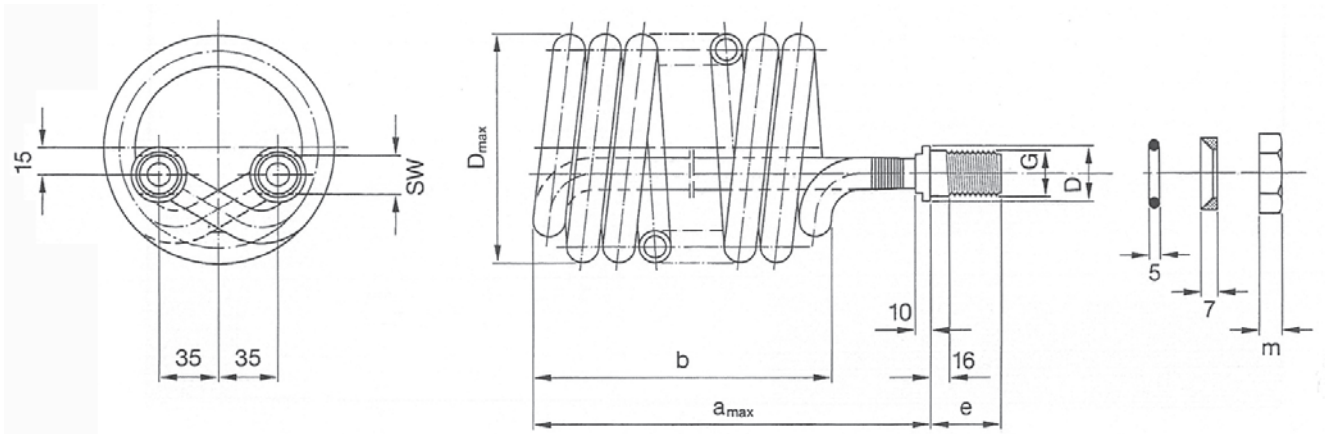

Design

The suitable heat exchanger is chosen according to the required outside surface which is calculated as follows:

$$A = \frac{\dot{Q}}{k \cdot \Delta t_m}$$

- A (m²) Outside surface of the heat exchanger
- \dot{Q} (W) Boiler capacity to be transferred
- k (W/m²K) Heat transfer coefficient referred to outside surface of the heat exchanger (empirical value: 800–1000 W/m²K)
- Δt_m (K) Mean logarithmic temperature difference (assumed water temperature at outlet of 35–40 °C).

Mounting of the Heat Exchanger

WRW heat exchangers are mostly mounted into hot water tanks. They are mounted into the (cold) bottom part of the tank if heat is to be added and into the (hot) upper part of the tank if heat is to be withdrawn from the tank water.

Its position may be either horizontal (Fig. 1) or vertical (Fig. 2). The seal is generally placed on the outside of the tank (Fig. 3), in some cases on the inside (Fig. 4). If the flange is less than 8 mm in thickness, a spacer (not supplied by Wieland) must be added between hollow disk and nut (Fig. 5). When fixing the nut, it is imperative to counterhold at the fitting flats.

For the EPDM-sealing element lubricants which contain mineral oil should not be used.

The WRW heat exchanger must be supported in the tank for transportation as well as operation to avoid mechanical damage of the heat exchanger.

Accessories

Defective coating of the tank may lead to corrosion of the tank if there is no electric insulation between tank, piping and heat exchanger. For this purpose, we are offering various sets of insulating elements available upon request.

For details, please refer to a special leaflet available upon request.

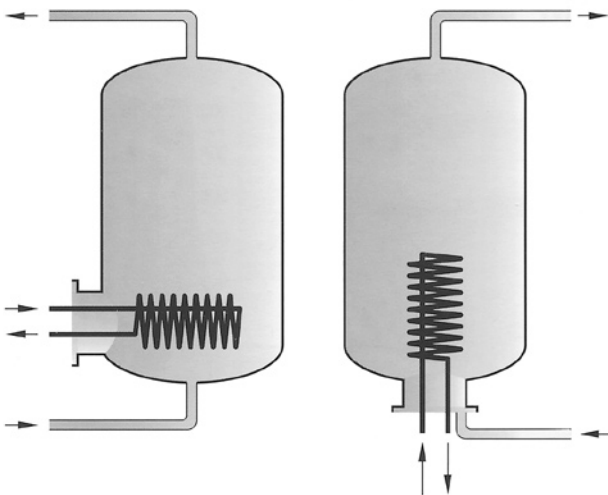

Fig. 1
Horizontal position

Fig. 2
Vertical position

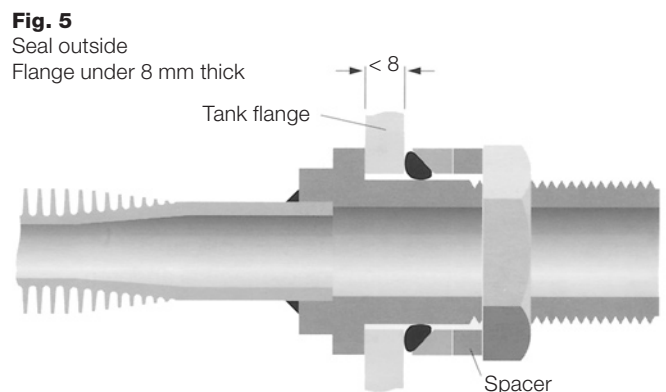
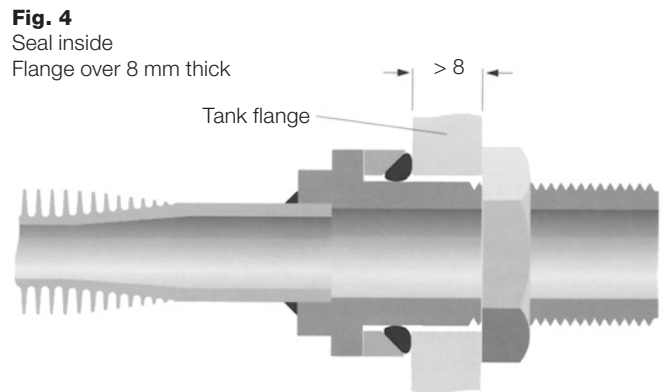
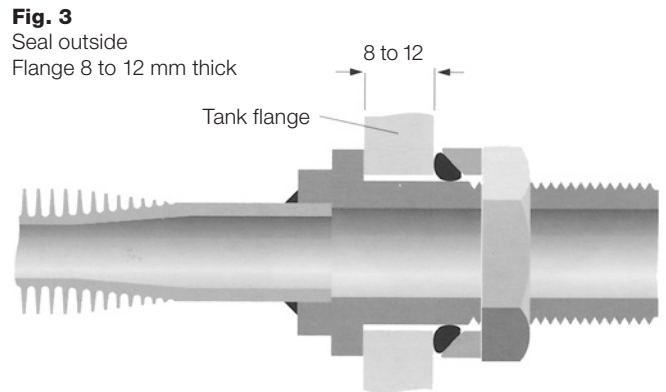

Fig. 5
Seal outside
Flange under 8 mm thick



Wieland-Werke AG

www.wieland-thermalsolutions.com

Tube Division

Graf-Arco-Str. 36, 89079 Ulm, Germany, Phone +49 (0)731 944-0, Fax +49 (0)731 944-2213, info@wieland.com

This brochure is designed for general information purposes only. With the exception of deliberate intent and gross negligence, no liability can be accepted for its correctness and completeness. Product characteristics are not assured. This brochure cannot replace individual consultation and own verification by the customer.